

REV.	DESCRIPTION	NCR#	DCR#	BY	DATE	APPROVED

**DRAWING APPROVED**  
**NAME:** \_\_\_\_\_  
**DATE:** \_\_\_\_\_  
**SIGNATURE:** \_\_\_\_\_

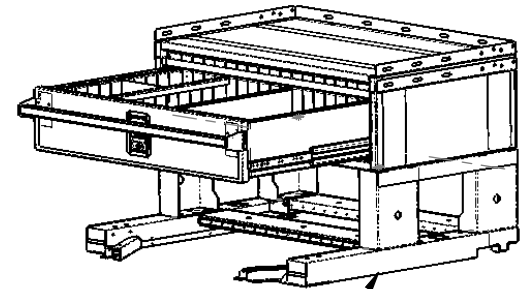
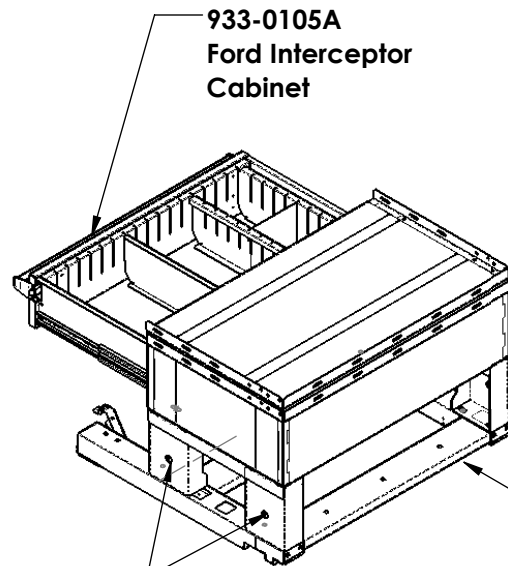
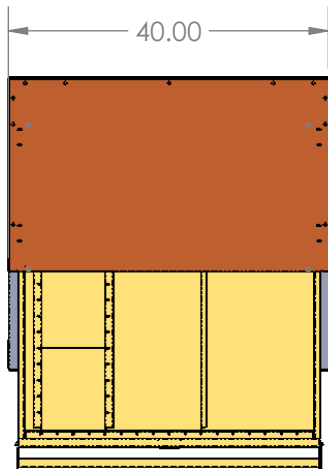

**Hardware List:**

- 8pc 3/8-16 Hex Bolt 1in**
- 8pc 3/8 Lock Washer**
- 8pc 3/8 Fender Washer**

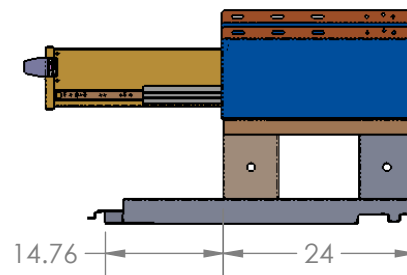
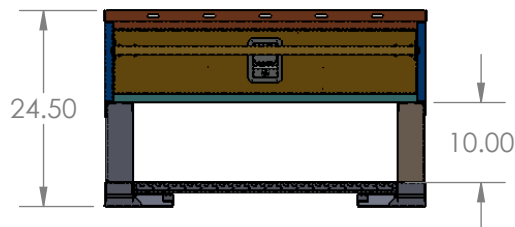

	NAME	DATE	<b>ELECTRONICS CO., LTD.</b> DANDR-ANSI-A REV2 APRIL 1, 2009	SIZE
DRAWN	VM	05/30/17		<b>A</b>
CHECKED	AD	05/30/17	Path: Y:\M\MECH_DATA\933 Storage Drawers\933-0127A Ford Interceptor Cabinet Stands AS File: 933-0127A Date: Friday, June 16, 2017 2:32:46 PM DESCRIPTION:	
THE INFORMATION CONTAINED WITHIN THIS DRAWING IS PROPRIETARY AND CONFIDENTIAL AND IS THE SOLE PROPERTY OF DandR ELECTRONICS CO., LTD. IT MAY NOT BE REPRODUCED AT WHOLE OR IN PART WITHOUT THE WRITTEN PERMISSION OF DandR ELECTRONICS CO., LTD.			<b>Ford Interceptor Cabinet with Stands</b>	
FINISH	MATERIAL		MFG. NO. <b>933-0127A</b> USED ON: - MATERIAL SEE TABLE	CATALOG. NO.  SHEET 1 OF 1 REV. <b>0</b>