

**See Sheet 2 for Assembly Instructions**

REV.	DESCRIPTION	BY	DATE	APPROVED
------	-------------	----	------	----------

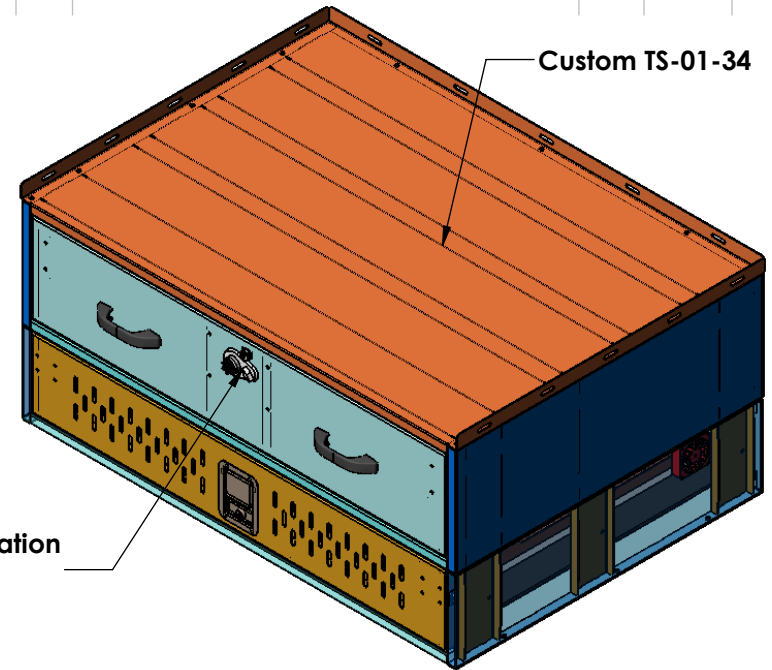
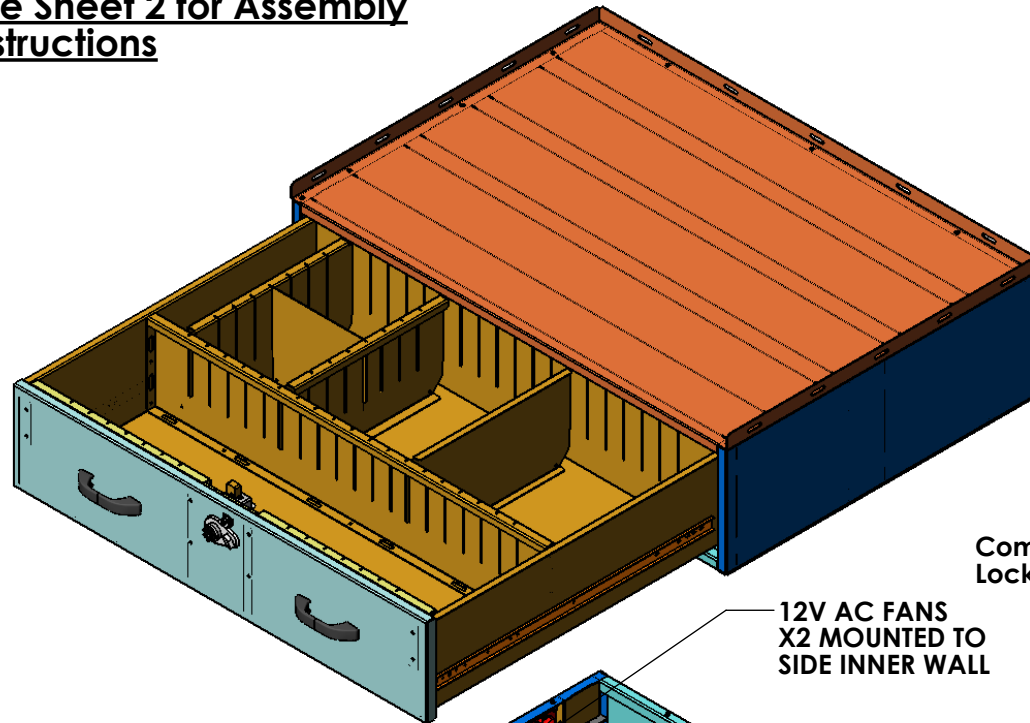

12V AC FANS  
X2 MOUNTED TO  
SIDE INNER WALL

Combination  
Lock

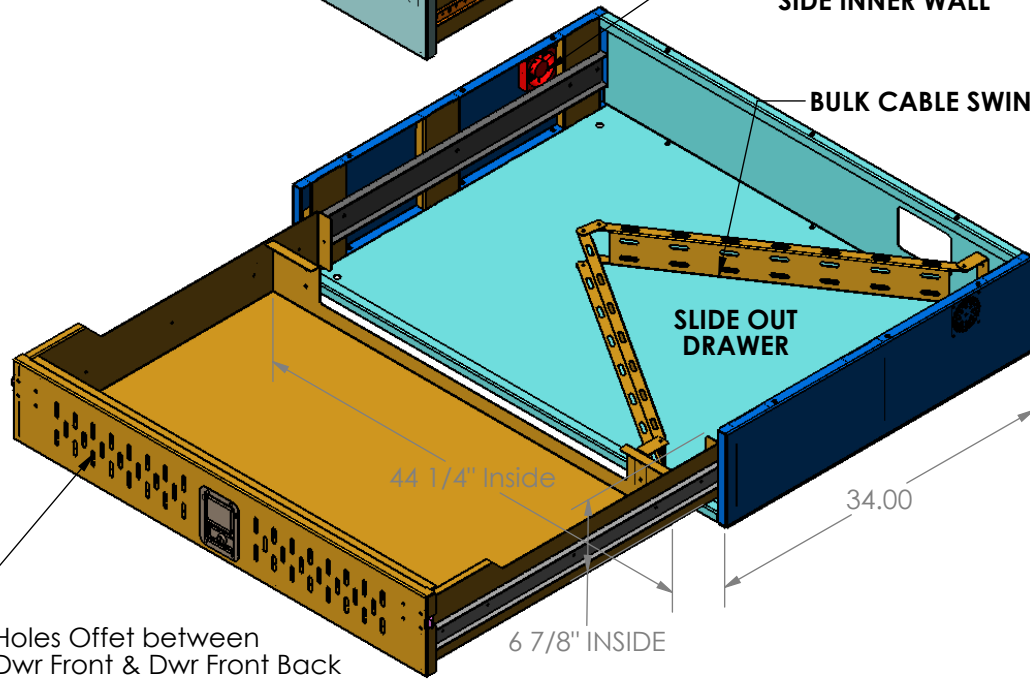

BULK CABLE SWING ARM

SLIDE OUT  
DRAWER

44 1/4" Inside

34.00

6 7/8" INSIDE

Holes Offet between  
Dwr Front & Dwr Front Back

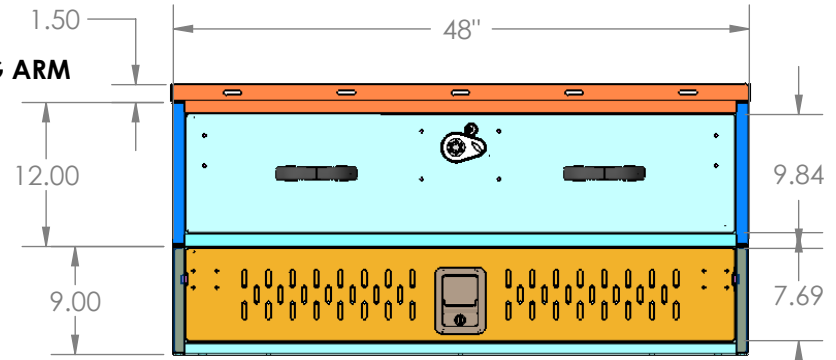

NAME	DATE	<b>ELECTRONICS CO., LTD.</b> DANDR-ANSI-A REV2 APRIL 1, 2009	SIZE
DRAWN	JVYAS 16FEB12		<b>A</b>
CHECKED		Path: Y:\M\ARCHIVE\934-Files\934-0516A Independence Missouri Custom Cabinet File: 934-0516A Date: Friday, June 30, 2017 3:31:00 PM	
THE INFORMATION CONTAINED WITHIN THIS DRAWING IS PROPRIETARY AND CONFIDENTIAL. AND IS THE SOLE PROPERTY OF DandR ELECTRONICS CO. LTD. IT MAY NOT BE REPRODUCED AT WHOLE OR IN PART WITHOUT THE WRITTEN PERMISSION OF DandR ELECTRONICS CO. LTD.		DESCRIPTION: <b>Dual Drawer Electronic                  Storage Cabinet</b>	
		MFG. NO. <b>934-0516A</b>	CATALOG. NO.
		USED ON:	SHEET 1 OF 1
FINISH	MATERIAL	REV.	
MIDNIGHT BLACK WRINKLE	0.090" ALUMINUM	0	

**Each Drawer has 32" Heavy Duty Full Extension Slides**

**Assembly Instructions:**

- Order 2X 12 V Fans, Part# 210-0015
- Install 2X Fans with filter.
- Run extension cable from fans till opening on cabinet back.
- Drill 4x 1/8" Holes on Cabinet Base Lip.
- Use cable cover and ziptie to conseal.
- Leave 2 feet of cable from hole opening.

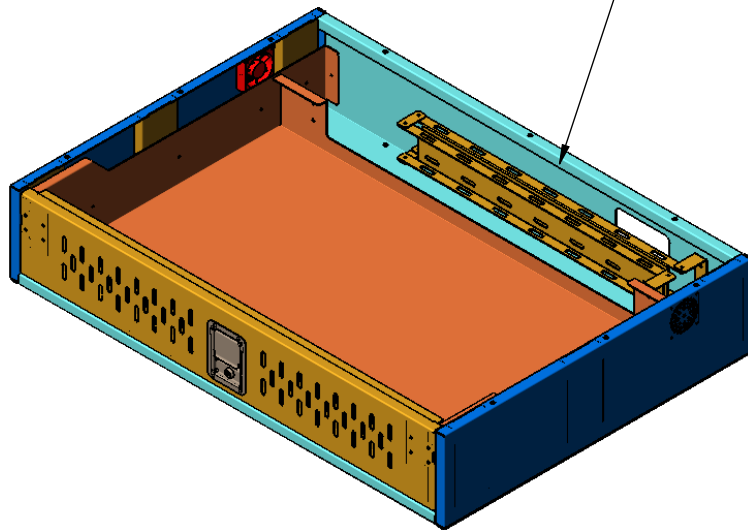

**Bottom Dwr Closed View**

REV.	DESCRIPTION	BY	DATE	APPROVED

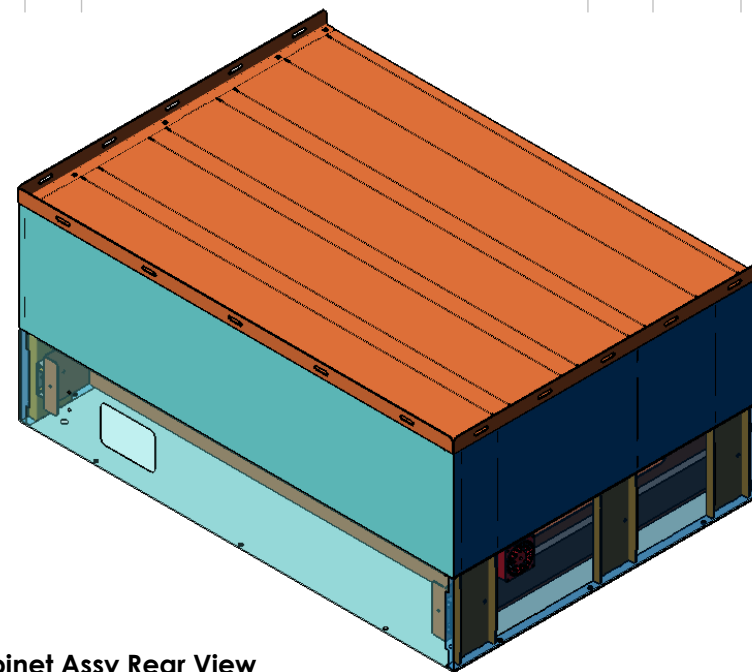

**Cabinet Assy Rear View**

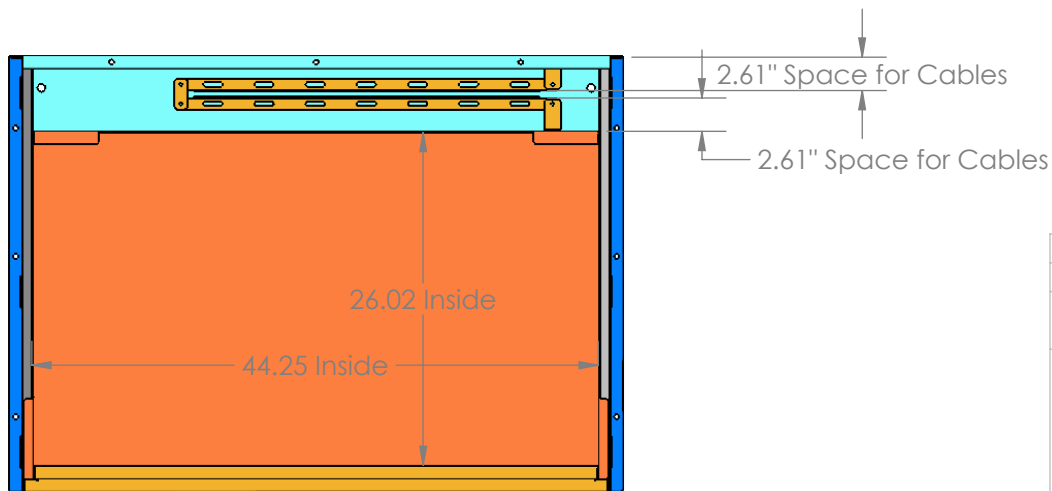
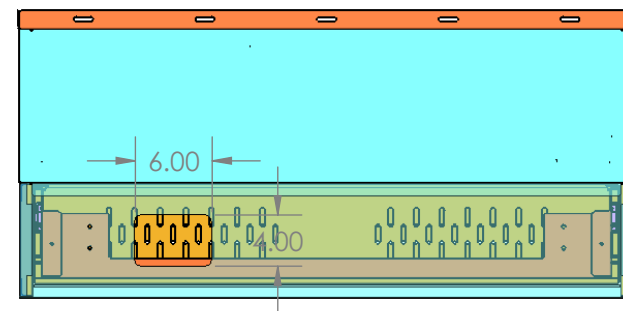

**Bottom Dwr Closed Top View**

	NAME	DATE	<b>ELECTRONICS CO., LTD.</b> DANDR-ANSI-A REV2 APRIL 1, 2009	SIZE
DRAWN	JVYAS	16FEB12		<b>A</b>
CHECKED			Path: Y:\M\ARCHIVE\934-Files\934-0516A Independence Missouri Custom Cabinet\ File: 934-0516A Date: Friday, June 30, 2017 3:31:00 PM	
THE INFORMATION CONTAINED WITHIN THIS DRAWING IS PROPRIETARY AND CONFIDENTIAL. AND IS THE SOLE PROPERTY OF DandR ELECTRONICS CO. LTD. IT MAY NOT BE REPRODUCED AT WHOLE OR IN PART WITHOUT THE WRITTEN PERMISSION OF DandR ELECTRONICS CO. LTD.			DESCRIPTION: <b>Dual Drawer Electronic Storage Cabinet</b>	
			MFG. NO. <b>934-0516A</b>	CATALOG. NO.
			USED ON:	SHEET 1 OF 1
FINISH MIDNIGHT BLACK WRINKLE			MATERIAL 0.090" ALUMINUM	REV. <b>0</b>