

REV.	DESCRIPTION	DATE	APPROVED

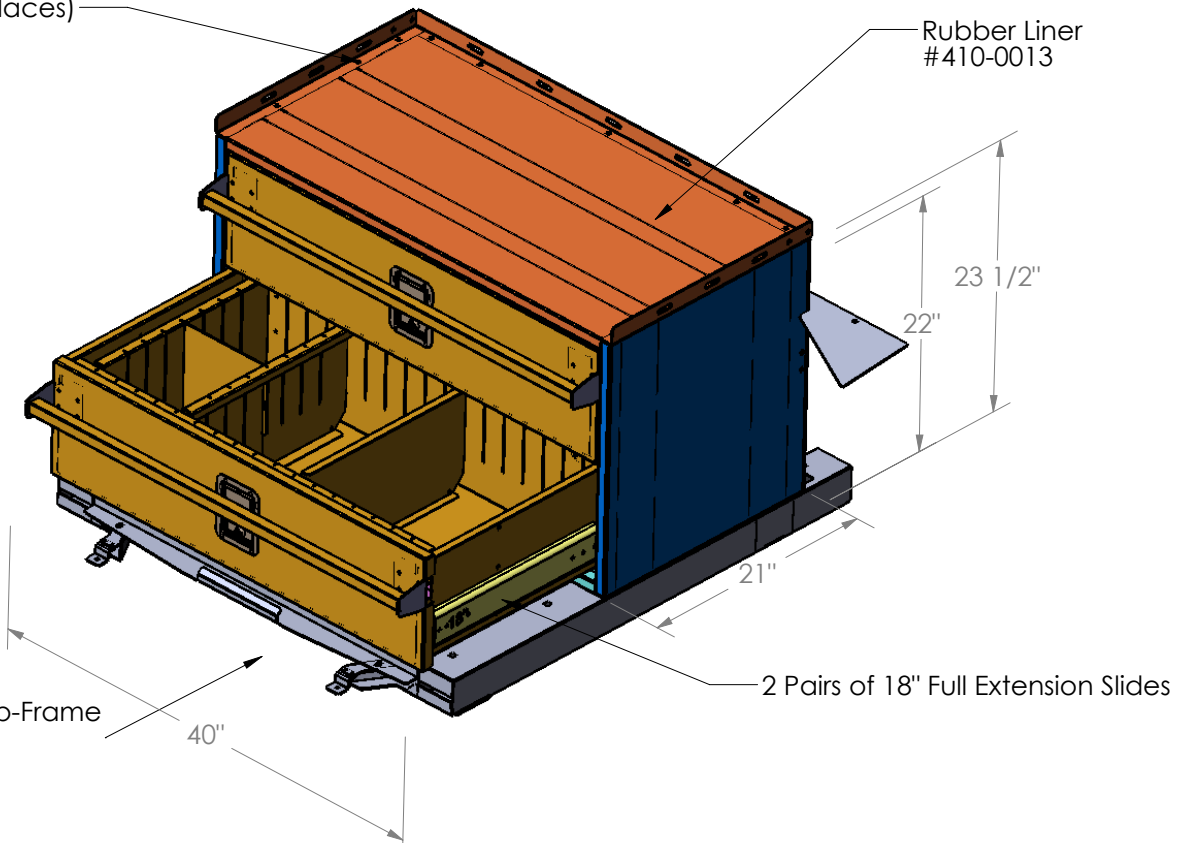
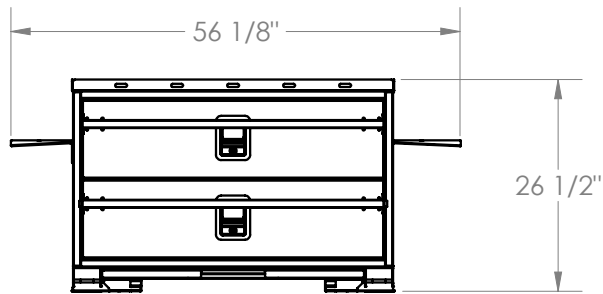
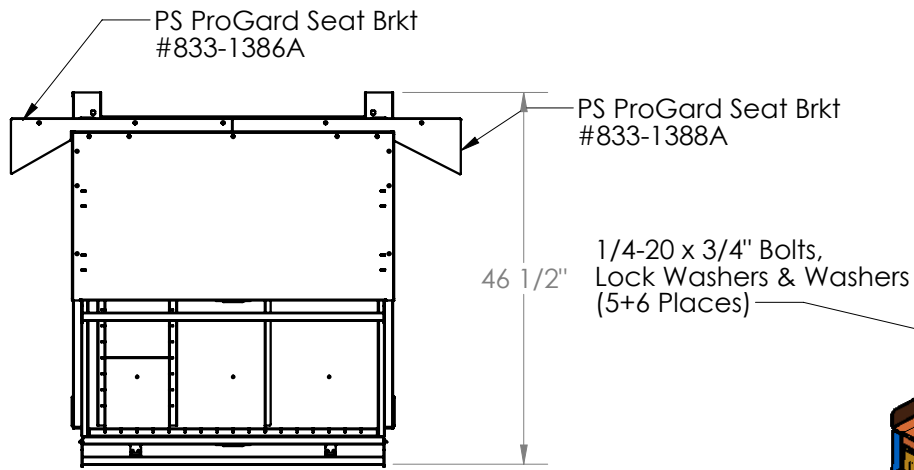

Ford Interceptor Utility Sub-Frame 933-0092A

DIMENSIONS ARE IN INCHES TOLERANCES: FRACTIONAL ± 1/32 ANGULAR: ± .10° TWO PLACE DECIMAL ± .010 THREE PLACE DECIMAL ± .005		NAME	DATE	<p>TS-02 Cabinet 40WX21DX22H With ProGard Brkt</p> <p>Path: Y:\MECH ENG\MECH_DESIGN\934-0567A TS02-Cabinet 40X26X12\ File: 934-0607A Date: Wednesday, May 01, 2013 8:03:17 AM SIZE DWG. NO. 934-0607A REV. 0</p>
MATERIAL	DRAWN	MQ		
FINISH	CHECKED			
	ENG APPR.			
	MFG APPR.			
Midnight Black Wrinkle	Q.A.			
	COMMENTS:			

Ensure Holes On Subframe Align Before Shipping

REV.	DESCRIPTION	DATE	APPROVED

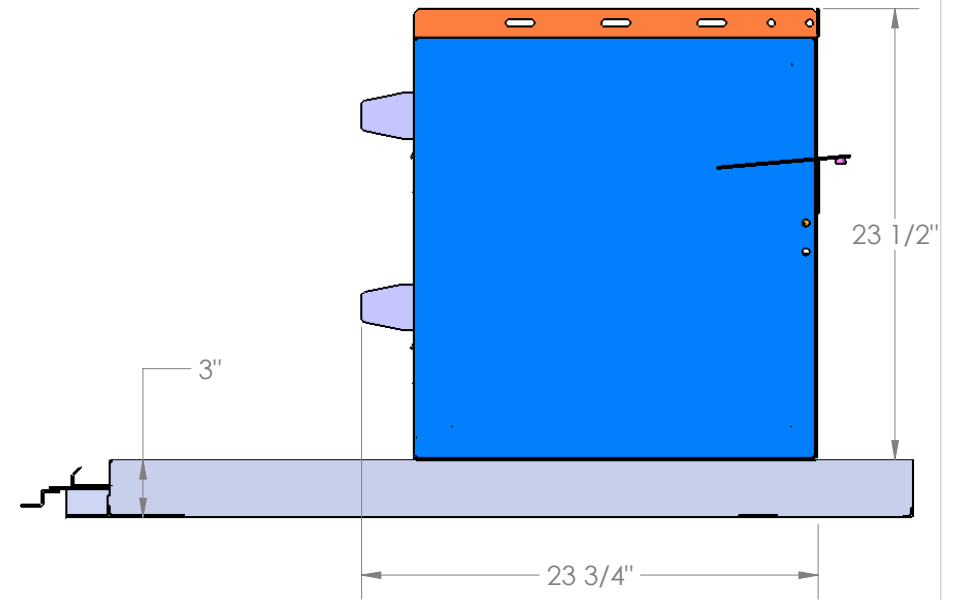
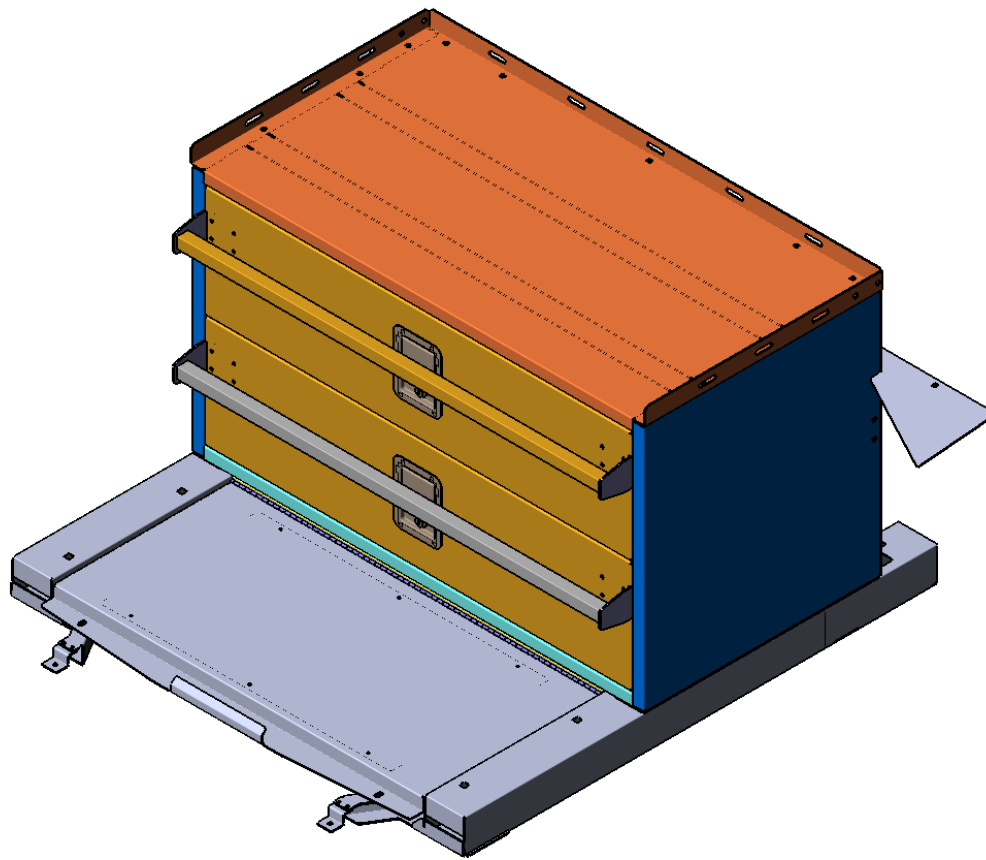

DIMENSIONS ARE IN INCHES TOLERANCES: FRACTIONAL $\pm 1/32$ ANGULAR: $\pm .10^\circ$ TWO PLACE DECIMAL $\pm .010$ THREE PLACE DECIMAL $\pm .005$		NAME MQ	DATE	
MATERIAL	CHECKED	ENG APPR.	MFG APPR.	TS-02 Cabinet 40WX21DX22H With ProGard Brkt
FINISH Midnight Black Wrinkle	Q.A.	COMMENTS:		
Path: Y:\MECH ENG\MECH_DESIGN\934-0567A TS02-Cabinet 40X26X12\ File: 934-0607A Date: Wednesday, May 01, 2013 8:03:17 AM		SIZE A	DWG. NO. 934-0607A	REV. 0
USED ON:			SHEET 2 OF 2	