

REV.	DESCRIPTION	BY	DATE	APPROVED

White Board Drawer
(White board Size: 22" x 16")

Motorola XTL5000 Radio Face Plate
With 2 x 12 Volt Power Outlets and
Mounting Holes for Microphone Clip
834-2840A

Cabinet Top Assy
834-2849A

Cabinet Assy
834-2850A

2 - FP Mtg Angle
834-2841A

5 Pair of heavy duty 26" Slide

2 Map Drawer With Hinged
Lexan Top
(Lexan size: 21.75" x 15.75")

2-Drawers With Dividers
(Inside 24.66"D x 16.75"W x 9.05"H)

NAME	DATE	DandR ELECTRONICS CO., LTD.		DANDR-ANSI-A	SIZE
DRAWN MQ	18FEB15			REV2	A
CHECKED AD	18FEB15			APRIL 1, 2009	
Path: Y:\M\MECH_DESIGN\934-0702A Priority1 Public Safety Explorer Storage\ File: 934-0702A Date: Friday, March 06, 2015 10:57:24 AM		DESCRIPTION:			
THE INFORMATION CONTAINED WITHIN THIS DRAWING IS PROPRIETARY AND CONFIDENTIAL. AND IS THE SOLE PROPERTY OF DandR ELECTRONICS CO. LTD. IT MAY NOT BE REPRODUCED AT WHOLE OR IN PART WITHOUT THE WRITTEN PERMISSION OF DandR ELECTRONICS CO. LTD.		Custom Explorer Storage Priority 1 Public Safety			
FINISH Midnight Black Wrinkle		MFG. NO. 934-0702A	CATALOG. NO. XXX		
		USED ON:			SHEET 1 OF 3
		MATERIAL Alum/ CRS	REV.		0

REV.	DESCRIPTION	BY	DATE	APPROVED

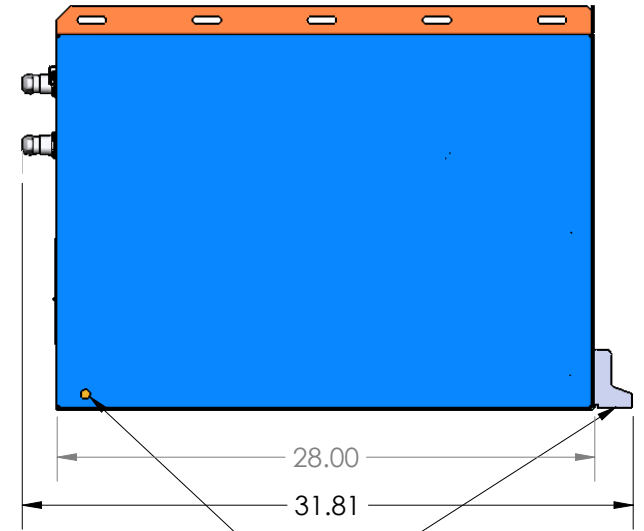
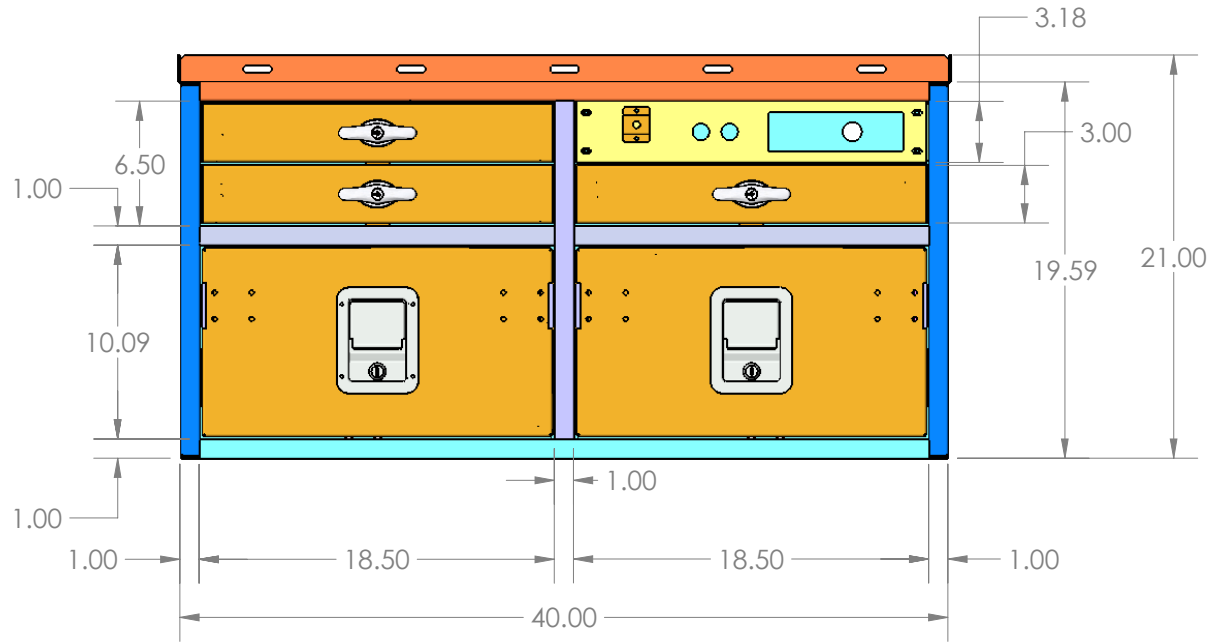

For lock with subframe

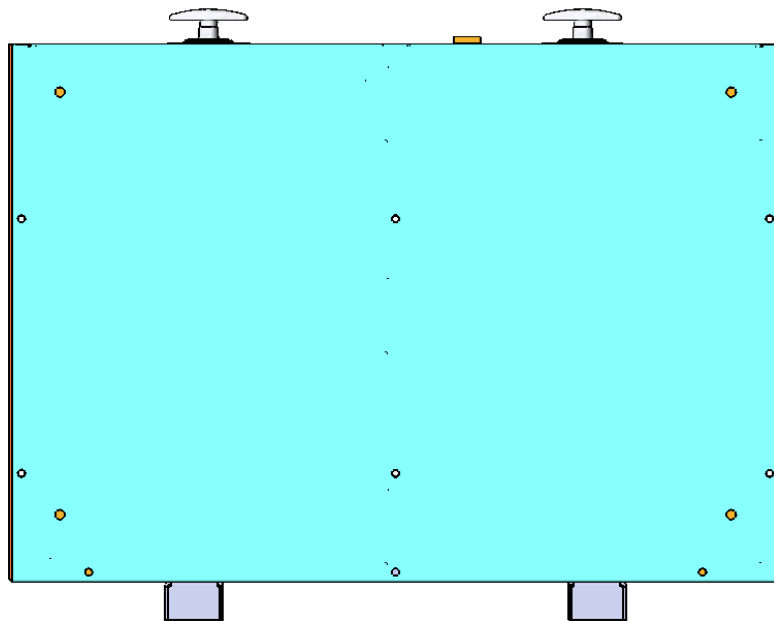

	NAME	DATE	 ELECTRONICS CO. LTD. DANDR-ANSI-A REV2 APRIL 1, 2009	SIZE
DRAWN	MQ	18FEB15		A
CHECKED	AD	18FEB15	Path: Y:\M\MECH_DESIGN\934-0702A Priority1 Public Safety Explorer Storage\ File: 934-0702A Date: Friday, March 06, 2015 10:57:24 AM	
THE INFORMATION CONTAINED WITHIN THIS DRAWING IS PROPRIETARY AND CONFIDENTIAL. AND IS THE SOLE PROPERTY OF DandR ELECTRONICS CO. LTD. IT MAY NOT BE REPRODUCED AT WHOLE OR IN PART WITHOUT THE WRITTEN PERMISSION OF DandR ELECTRONICS CO. LTD.			DESCRIPTION: Custom Explorer Storage Priority 1 Public Safety	
FINISH			MFG. NO.	CATALOG. NO.
Midnight Black Wrinkle			934-0702A	XXX
			USED ON:	SHEET 2 OF 3
			MATERIAL	REV.
			Alum/ CRS	0

REV.	DESCRIPTION	BY	DATE	APPROVED

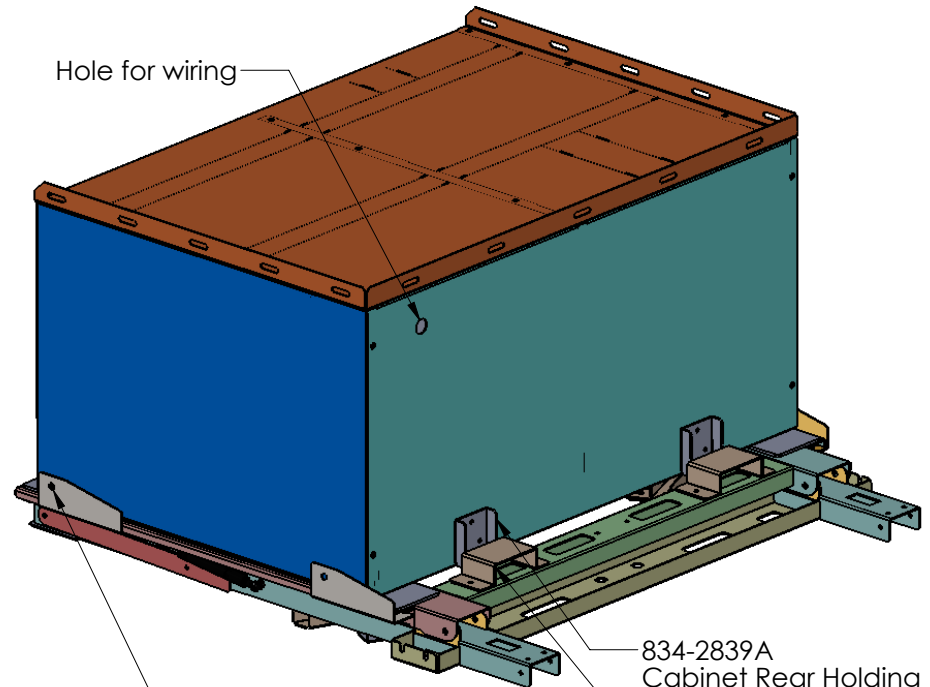
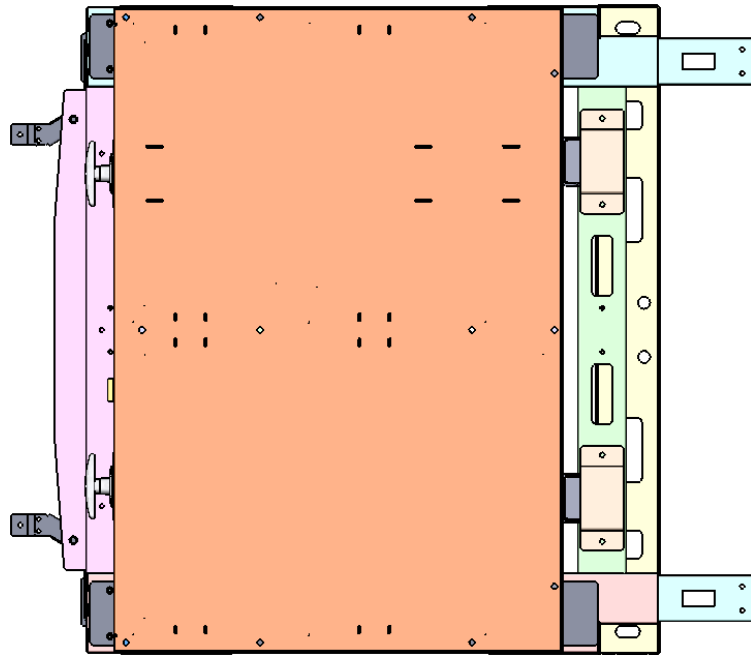

934-0702A
Custom Cabinet

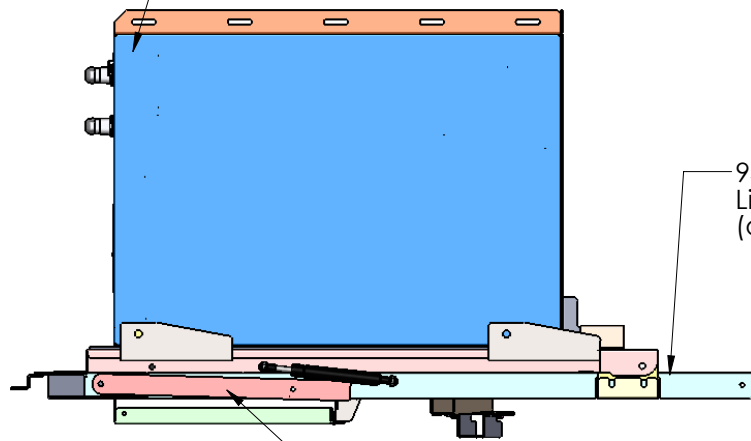

933-0113A
Liftable Subframe
(order seperately)

Safety Bar (2x)
Both Side

Hole for wiring

Both Side 3/8-16 Handle
Bolt Cabinet with Subframe

834-2839A
Cabinet Rear Holding Brkts

834-2838A
Subframe Hat Brkts
for Holding Cabinet

NAME	DATE	DANDR ELECTRONICS CO., LTD.		DANDR-ANSI-A	SIZE
DRAWN MQ	18FEB15			REV2	A
CHECKED AD	18FEB15			APRIL 1, 2009	
Path: Y:\M\MECH_DESIGN\934-0702A Priority1 Public Safety Explorer Storage\ File: 934-0702A Date: Friday, March 06, 2015 10:57:24 AM		DESCRIPTION:			
THE INFORMATION CONTAINED WITHIN THIS DRAWING IS PROPRIETARY AND CONFIDENTIAL. AND IS THE SOLE PROPERTY OF DandR ELECTRONICS CO. LTD. IT MAY NOT BE REPRODUCED AT WHOLE OR IN PART WITHOUT THE WRITTEN PERMISSION OF DandR ELECTRONICS CO. LTD.		Custom Explorer Storage Priority 1 Public Safety			
FINISH		MFG. NO.	CATALOG. NO.		
Midnight Black Wrinkle		934-0702A	XXX		
		USED ON:	SHEET 3 OF 3		
		MATERIAL	REV.		
		Alum/ CRS	0		