

REV.	DESCRIPTION	BY	DATE	APPROVED

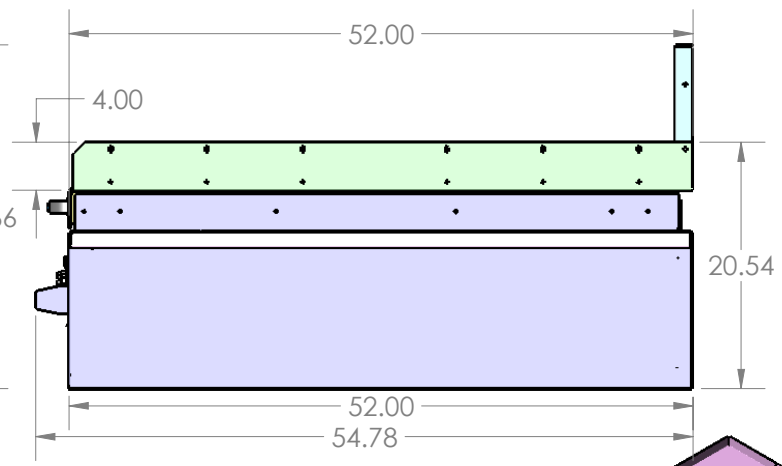

3 Pairs of 48" Travel Heavy Duty Slide

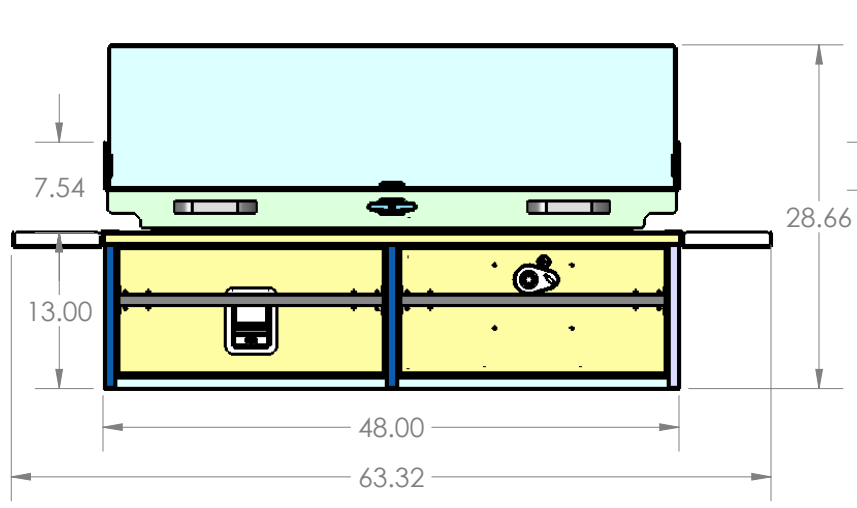
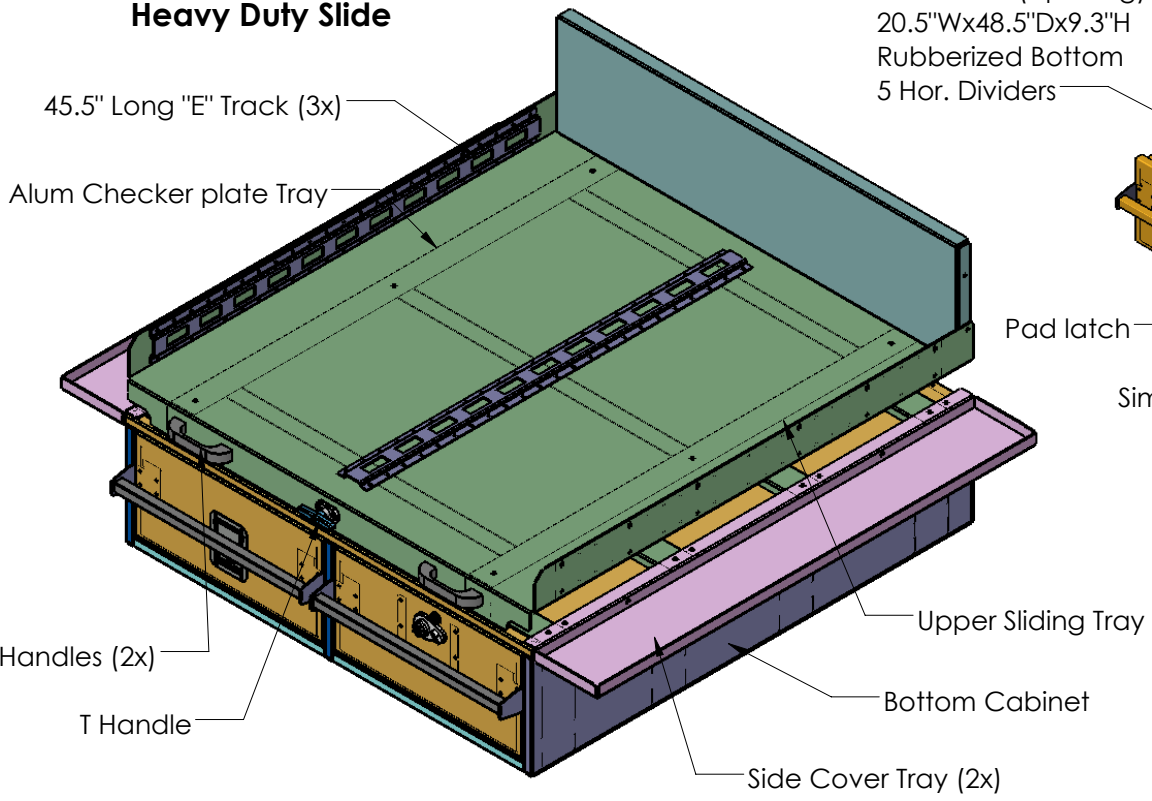

DS Drawer (opening)
20.5"Wx48.5"Dx9.3"H
Rubberized Bottom
5 Hor. Dividers

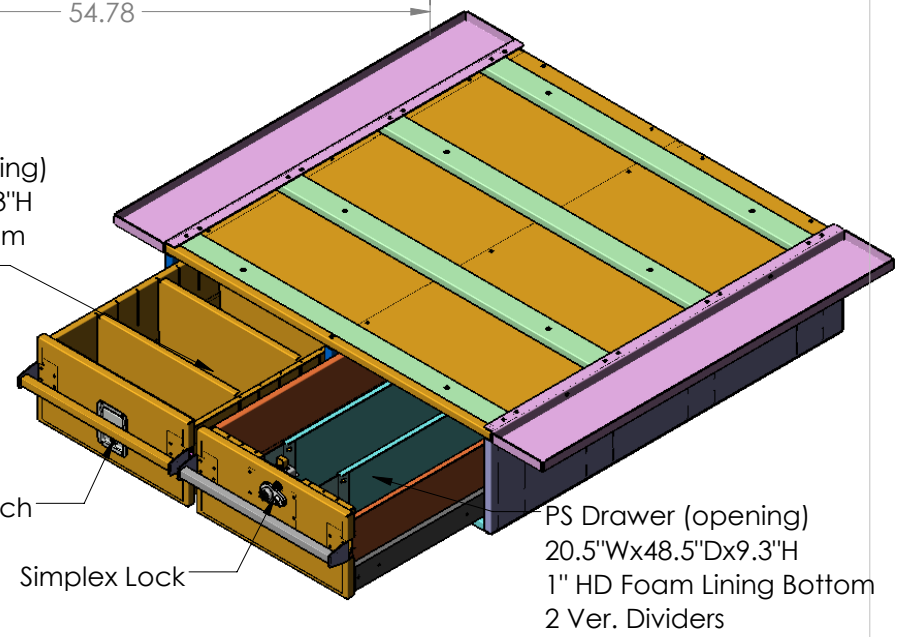

DRAWN	NAME MQ	DATE 31MAR16	ELECTRONICS CO., LTD. DANDR-ANSI-A REV2 APRIL 1, 2009	SIZE A
CHECKED	AD	31MAR16		Path: Y:\M\MECH_DESIGN\934-0749A Custom Stor Sys Silverado1500 5FT\ File: 934-0749A Date: Friday, April 01, 2016 9:48:24 AM DESCRIPTION: Custom Storage System 2 Drawer Cabinet with top Slide Deck For Chevy Silerado1500 5FT Box
THE INFORMATION CONTAINED WITHIN THIS DRAWING IS PROPRIETARY AND CONFIDENTIAL. AND IS THE SOLE PROPERTY OF DANDR ELECTRONICS CO. LTD. IT MAY NOT BE REPRODUCED AT WHOLE OR IN PART WITHOUT THE WRITTEN PERMISSION OF DANDR ELECTRONICS CO. LTD.			MFG. NO. 934-0749A	CATALOG. NO.
FINISH Midnight Black Wrinkle			MATERIAL Cabinet: 0.090" Alum; 1/8" Alum Checker Plate	SHEET 1 OF 1 REV. 0